



Crawford Drawbridge dock levellers

Copyright and Disclaimer Notice

Although the contents of this publication have been compiled with the greatest possible care, ASSA ABLOY Entrance Systems cannot accept liability for any damage that might arise from errors or omissions in this publication. We also reserve the right to make appropriate technical modifications/replacements without prior notice.

No rights can be derived from the contents of this document.

Color guides: Color differences may occur due to different printing and publication methods.

ASSA ABLOY, Crawford, Megadoor and hafa, as words and logos, are examples of trademarks owned by ASSA ABLOY Entrance Systems or companies within the ASSA ABLOY Group.

Copyright © ASSA ABLOY Entrance Systems 2006-2013.

No part of this publication may be copied or published by means of scanning, printing, photocopying, microfilm or any other process whatsoever without prior permission in writing by ASSA ABLOY Entrance Systems.

All rights reserved.



Contents

Copyright and Disclaimer Notice	2
Contents	3
1. 640 Drawbridge DMW	4
1.1 Application	4
1.2 Mode of operation	4
1.3 Dimensions	4
1.4 Operating handle	4
1.5 Building specifications	5
1.5.1 Dock edge preparation	5
1.5.2 Installation to the dock edge	5
2. 641 Drawbridge DMGZ	6
2.1 Application	6
2.2 Mode of operation	7
2.3 Dimensions	7
2.4 Operating handle	7
2.5 Building specifications	7
2.5.1 Dock edge preparation	7
2.5.2 Installation to the dock edge	8
3. Selection guide	9
3.1 Load capacity according to EN 1398	9
3.1.1 Rated load	9
3.1.2 Axle load	9
3.1.3 Dynamic load	9
3.2 Select the load capacity	9
3.2.1 Example	9
4. Service	10
Index	11



1. 640 Drawbridge DMW

1.1 Application

The Crawford 640 drawbridge DMW is a fixed drawbridge, designed for the higher working range up to 300 mm level equalisation.

Thanks to the aluminium segment lip construction there is safe contact between lip and lorry bed, even when the lorry bed is not in a horizontal line. With all steel parts being hot galvanised the Crawford 640 drawbridge DMW is very durable and ideally suited for hygienic applications.

The new features of this dock leveller ensure that it complies with the new European EN 1398 standards.

1.2 Mode of operation

The Crawford 640 drawbridge DMW is fixed in position by welding it to a cast-in channel on the dock wall. The counter balance springs reduce the weight when manually positioning the leveller, and allow it to adjust to varying vehicle heights during the loading/unloading operation.

The aluminium alloy lip is segmented, which ensures it can accommodate a lateral deflection across the width of the docked vehicle. When not in use the leveller is stored vertically and can be padlocked to prevent unauthorised use.

1.3 Dimensions

NL	A*	B*
1200	175	245
1500	225	295
1750	265	340
2000	310	390

Nominal width NW for all sizes: 1500, 1750, 2000

Load capacity for all sizes: 60 kN

* Figures take into account the offset of the support segments

1.4 Operating handle

Standard

One operating handle for drawbridges of all sizes, except for 2000 mm * 2000 mm. Drawbridges of 2000 mm * 2000 mm must be operated by two persons, so two operating handles are installed.

Option

Additional operating handle (for all sizes, except 2000 mm * 2000 mm where it is standard).

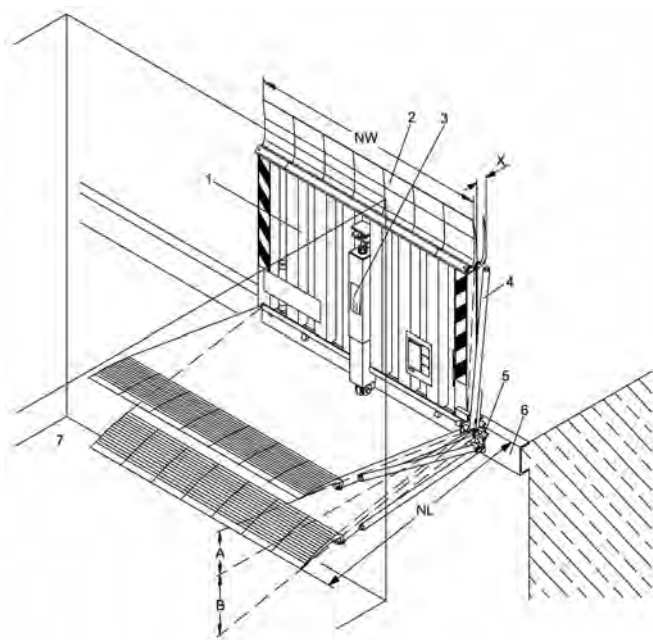

- 1 Leveller platform
- 2 Segmented aluminium alloy lip
- 3 Counter balance spring
- 4 Operating handle
- 5 Padlock
- 6 Cast-in channel
- 7 Vehicle bed
- NL Nominal length
(pivot point of hinge to edge of lip)
- NW Nominal width
- A Level equalisation above dock
- B Level equalisation below dock
- X Clearance 250 mm

1.5 Building specifications

1.5.1 Dock edge preparation

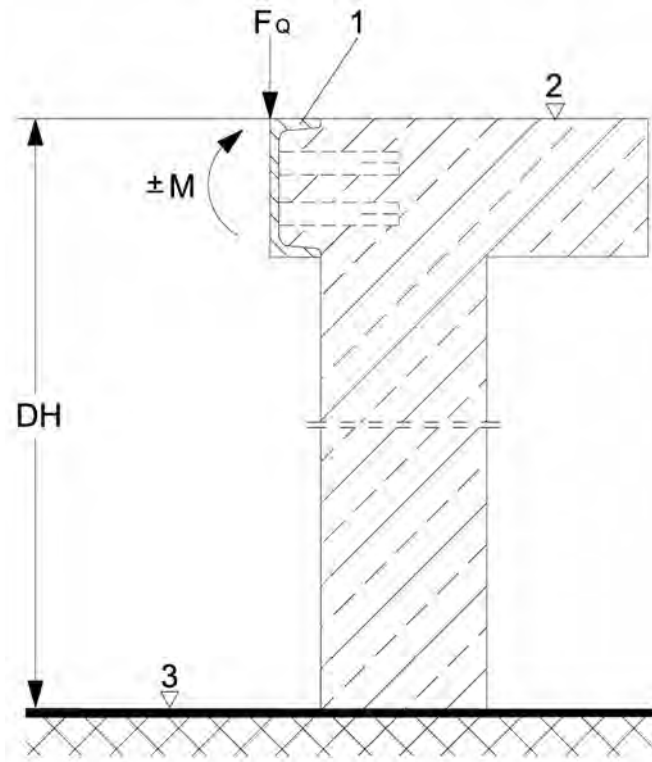

1.5.2 Installation to the dock edge

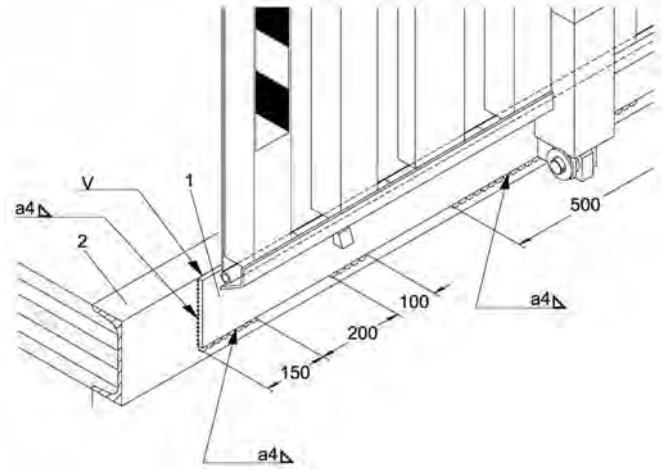

- 1 Guide rail
- 2 Cast-in channel

FQ	Transverse force = 84kN		
M	Maximum bending moment (kNm)		
DH	Dock height		
1	U 200 DIN 1026 or 203 x 76 RSC (recommended)		
2	Finished floor level		
3	Yard level		
NL	Maximum bending moment M exerted on the dock edge (kNm)		
	NW = 1500	NW = 1750	NW = 2000
1200	5,4	6,3	7,5
1500	8,3	9,0	10,1
1750	11,4	12,3	13,6
2000	14,0	16,0	17,0



2. 641 Drawbridge DMGZ

2.1 Application

The Crawford 641 drawbridge DMGZ is a drawbridge that moves sideways on guide rails, designed for the higher working range up to 300 mm level equalisation.

Thanks to the aluminium segment lip construction there is safe contact between lip and lorry bed, even when the lorry bed is not in a horizontal line. With all steel parts being hot galvanised the Crawford 641 drawbridge DMGZ is very durable and ideally suited for hygienic applications.

Also available is the Crawford 642 drawbridge DMGC. This model is identical, except for the guide rail. The Crawford 641 drawbridge DMGZ is designed for new installations with a simplified guide rail. The Crawford 642 drawbridge DMGC is designed for replacement of existing DMGC levellers, because the existing C-profile can then be re-used.

The new features of this dock leveller ensure that it complies with the new European EN 1398 standards.

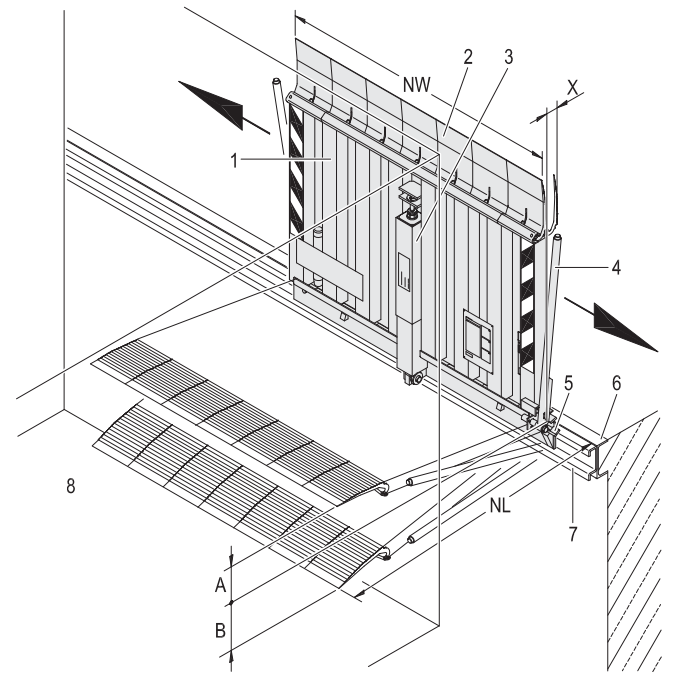

- | | |
|----|---|
| 1 | Leveller platform |
| 2 | Segmented aluminium alloy lip |
| 3 | Counter balance spring |
| 4 | Operating handle |
| 5 | Padlock |
| 6 | Cast-in channel |
| 7 | Guide rail |
| 8 | Vehicle bed |
| NL | Nominal length
(pivot point of hinge to edge of lip) |
| NW | Nominal width |
| A | Level equalisation above dock |
| B | Level equalisation below dock |
| X | Clearance 250 mm |

2.2 Mode of operation

The Crawford 641 drawbridge DMGZ is installed on bearings in a guide rail (supplied separately) which must in turn be fixed in position by welding to a cast-in steel channel on the dock wall. The Crawford 641 drawbridge DMGZ can then be finitely positioned by sliding it along the rail.

The Crawford 641 drawbridge DMGZ is operated manually by releasing the lock on the handle(s) and lowering the platform onto the vehicle bed. The counter balance springs reduce the weight when manually positioning the leveller, and allow it to adjust to varying vehicle heights during the loading/unloading operation.

The aluminium alloy lip is segmented, which ensures it can accommodate a lateral deflection across the width of the docked vehicle. When not in use the leveller is stored vertically and can be padlocked to prevent unauthorised use.

2.3 Dimensions

NL	A*	B*
1200	175	245
1500	225	295
1750	265	340
2000	310	390

Nominal width NW for all sizes: 1500, 1750, 2000

Load capacity for all sizes: 60 kN

* Figures take into account the offset of the support segments

2.4 Operating handle

Standard

One operating handle for drawbridges of all sizes, except for 2000 mm * 2000 mm. Drawbridges of 2000 mm * 2000 mm must be operated by two persons, so two operating handles are installed.

Option

Additional operating handle (for all sizes, except 2000 mm * 2000 mm where it is standard).

2.5 Building specifications

2.5.1 Dock edge preparation

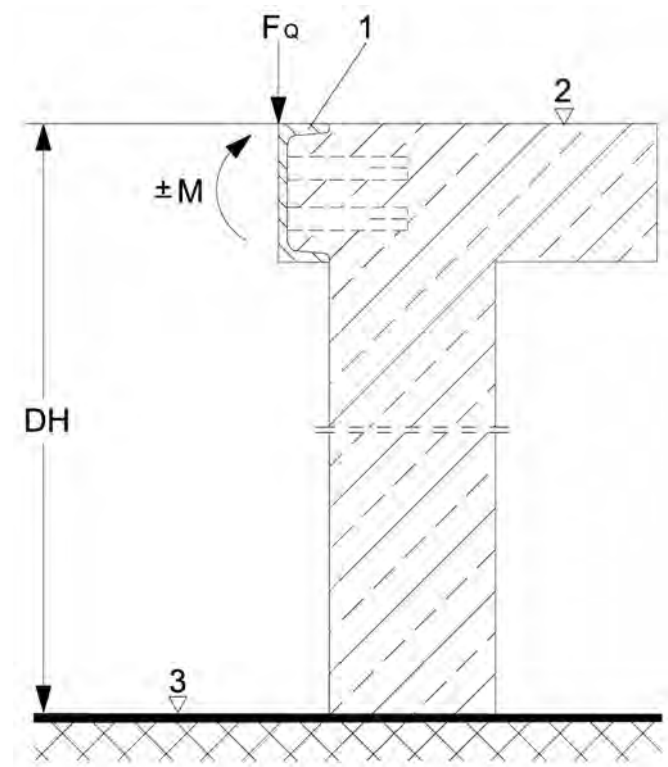

FQ	Transverse force = 84kN		
M	Maximum bending moment (kNm)		
DH	Dock height		
1	U 200 DIN 1026 or 203 x 76 RSC (recommended)		
2	Finished floor level		
3	Yard level		
NL	Maximum bending moment M exerted on the dock edge (kNm)		
	NW = 1500	NW = 1750	NW = 2000
1200	5,4	6,3	7,5
1500	8,3	9,0	10,1
1750	11,4	12,3	13,6
2000	14,0	16,0	17,0



2.5.2 Installation to the dock edge

641 drawbridge DMGZ guide rail (new installation)

642 drawbridge DMGC guide rail (already existing)

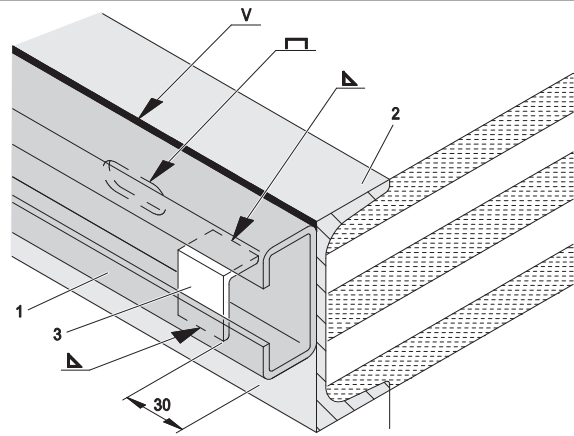
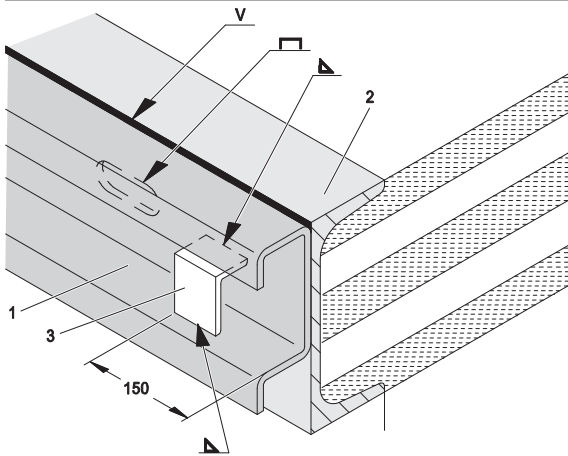

- 1 Guide rail
- 2 Cast-in channel
- 3 End stop

3. Selection guide

3.1 Load capacity according to EN 1398

The EN 1398 describes 3 key definitions about loads.

3.1.1 Rated load

The rated load is the total weight of the goods, the forklift truck and the driver.



3.1.2 Axle load

Axle loads shall be taken acting over two rectangular contact areas at 1 m lateral distance. These areas shall only apply if the actual conditions do not call for more severe loading. The size of the footprint [mm²] is derived from the wheel load [N] divided by 2 [N/mm²]. The ratio of the rectangular print is W:L = 3:2.

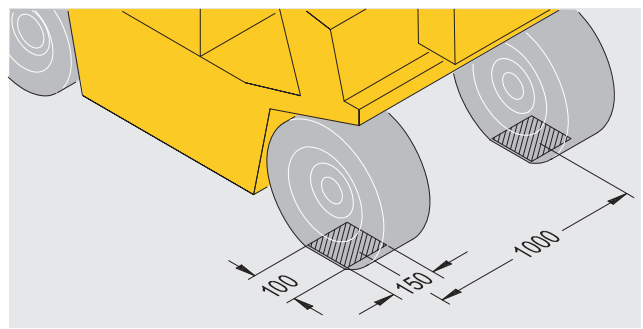

In the drawing measures for a leveller with a load capacity of 60kN are shown.

3.1.3 Dynamic load

The dynamic load is the movement of the rated load and is the pressure on the leveller platform caused by the moving forklift truck.

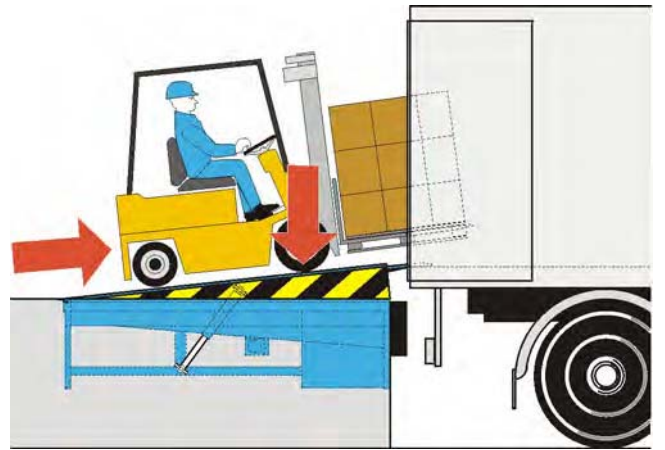

3.2 Select the load capacity

The load capacity of a dock leveller must always be higher than the rated load.

3.2.1 Example

Weight of forklift truck	3600 kg
Weight of goods	1500 kg
Weight of driver	100 kg
Total weight/rated load	5200 kg
Suitable load capacity of the leveller	6000 kg/60kN



4. Service

Preventive Maintenance Program and Modernization Services

As your entrances are part of your business flow, there's every reason to keep them working well. ASSA ABLOY Entrance Systems offers you a maintenance and modernization expertise to rely on. Our Maintenance Programs and Modernization Services are backed by a extensive expertise for all types of industrial door and docking systems, independent of brand. At your disposal is a team of dedicated expert technicians, proven through decades of maintenance, service and satisfied customers.

Preventive Maintenance Programs

Minimizing lost time, lost energy and unexpected hassle is our team's constant objective. Our service organization can support you 24/7 in maintaining all industrial door and docking systems, independent of brand. If you want to be one step ahead of break-downs, explore our portfolio of Pro-Active Care plans. Naturally, we also offer entrance upgrades to suit your specific wishes and business needs.

Pro-Active Care - Maintenance plans to fit your business

Regular maintenance can extend the lifetime of your equipment and help prevent unexpected problems. Our technician arrives on-site equipped with the knowledge and tools to service all automatic entrances, independent of brand.

- **Pro-Active Bronze**

The base on which all Pro-Active Plans are built provides the security of knowing that your equipment is regularly inspected and certified for safety, as well as performing optimally. It includes a number of planned on-site visits depending on your needs. Any unplanned service calls required during the term of the contract (including labor, travel and parts) are billed at special Pro-Active Care prices.

- **Pro-Active Silver**

This plan provides all the benefits of Pro-Active Bronze with the added advantage of labor and travel being included for service calls during regular business hours. The only additional charge would be for any parts that may be needed throughout the term of the contract.

- **Pro-Active Gold**

This plan provides the ultimate protection for your automatic entrance investment. It includes all the benefits of Pro-Active Silver, plus replacement of any parts required during an unplanned repair or planned maintenance visit. Pro-Active Gold is an excellent way to budget your automatic door expenses annually.

- **Pro-Active Tailor-Flex**

Our most flexible maintenance and service offering. The Pro-Active Care plan is designed by you, our customer. The plan allows you to balance your maintenance expenses against your real-world budget and presents the option to add or delete a number of maintenance elements to suit your budget goals, while meeting your overall performance and safety needs.

Modernization

Your entrances are a long-term investment, from which you always want the best. Products develop over time, so do regulations and your business. Let us help you increase energy savings and meet today's standards. We provide advice and modernization kits for outdated installations, ensuring your investment meet requirements and performs optimally for many more years to come.

Re-Active Service		Pro-Active Care				
		Pro-Active Bronze	Pro-Active Silver	Pro-Active Gold	Pro-Active Tailor Flex	
		○	○	○	●	Other customized requests such as Response Time, Performance InfoPack and Advanced User Training
		○	○	●	○	Replacement of worn parts according to preventive Consumable Exchange Program
		○	○	●	○	Replacement of spare parts on breakdowns
		○	●	●	○	Travel and labor for additional call-out visits
		●	●	●	●	Preventive maintenance visits 1-4 times per year
		●	●	●	●	Travel and labor for preventive maintenance visits
		●	●	●	●	Response time and priority on call-outs <24h
		●	●	●	●	Preventive planned maintenance that meets the most demanding standards in the market
	●	●	●	●	●	Safety and quality checks according to applicable regulations and norms. Documentation of test results provided
●	●	●	●	●	●	Documentation of equipment status, assessment and service provided, all generated on site
●	●	●	●	●	●	Highly trained professional technicians with extensive knowledge, state-of-the-art tools and the right spare parts*
●	●	●	●	●	●	Dedicated Professional Customer Care Hotline
Corrective	SafetyCheck	Pro-Active Bronze	Pro-Active Silver	Pro-Active Gold	Pro-Active Tailor Flex	

● = Included as standard

○ = Available at special prices

* Well-stocked service vehicles with genuine and new spare parts

Index

Numerics

640 Drawbridge DMW4

641 Drawbridge DMGZ6

A

Application4, 6

Axle load9

B

Building specifications5, 7

C

Copyright and Disclaimer Notice2

D

Dimensions4

Dock edge preparation5

Dynamic load9

E

Example9

I

Installation to the dock edge5, 8

L

Load capacity according to EN 1398 9

M

Mode of operation4, 7

O

Operating handle4

R

Rated load9

S

Select the load capacity9

Selection guide9

Service10

ASSA ABLOY Entrance Systems is a leading supplier of entrance automation solutions for efficient flow of goods and people. With our worldwide presence we offer products and services dedicated to satisfying end-user needs for safe, secure, convenient and sustainable operations. ASSA ABLOY Entrance Systems is a division within ASSA ABLOY.

ASSA ABLOY

www.assaabloyentrance.com