



## Crawford 671 Inflatable shelter SIR

# Copyright and Disclaimer Notice

Although the contents of this publication have been compiled with the greatest possible care, ASSA ABLOY Entrance Systems cannot accept liability for any damage that might arise from errors or omissions in this publication. We also reserve the right to make appropriate technical modifications/replacements without prior notice.

No rights can be derived from the contents of this document.

Color guides: Color differences may occur due to different printing and publication methods.

ASSA ABLOY, Crawford, Megadoor and hafa, as words and logos, are examples of trademarks owned by ASSA ABLOY Entrance Systems or companies within the ASSA ABLOY Group.

Copyright © ASSA ABLOY Entrance Systems 2006-2013.

No part of this publication may be copied or published by means of scanning, printing, photocopying, microfilm or any other process whatsoever without prior permission in writing by ASSA ABLOY Entrance Systems.

All rights reserved.



# Technical facts

## Features

Sizes - nominal height	4055, 4355, 4555 mm
Sizes - Free height	3600, 3900, 4100 mm
Sizes - nominal width	3600 mm
Sizes - nominal depth	770 mm
Sizes - top bag extension	2200 mm
Sizes - side bag extension	650 mm
Standard colour	RAL 9016
Control unit	Switch control

## Performance

Walls	Insulated panel 42 mm White RAL 9016
Roof	Insulated panel 42 mm White RAL 9016
Cover plate roof / wall	White RAL 9016
Front plate	Steel sheet painted white RAL 9016 with reinforcement angle
Surface treatment	Hot galvanised and painted with polyester paint, which corresponds to environmental class 3
Front protection	Yellow polyethene plastic
Fabric quality	Top curtain: PVC coated polyester fabric 650 g/m <sup>2</sup> , thickness 0,6 mm Side bag rear : made of PVC coated polyester fabric 600 g/m <sup>2</sup> , thickness 0,5 mm Side bag front: made of PVC coated polyester fabric 2500 g/m <sup>2</sup> , thickness 2 mm Option wear shield: PVC coated polyester fabric 3400 g/m <sup>2</sup> , thickness 3 mm
Fan	230 V, 1-phase, 50 Hz, 250 W Noise niveau: 65 dBA in working position
Operating	Switch control included. Other controls available as option
Temperature range	-30° to +60°

# Contents

Copyright and Disclaimer Notice .....	2
Technical facts .....	3
Contents .....	4
1. Description .....	5
1.1 Application .....	5
1.2 Mode of operation .....	5
1.3 Overview .....	5
1.4 Standard .....	5
1.5 Options .....	5
1.5.1 Option wear shield .....	5
2. Specifications .....	6
2.1 Dimensions .....	6
3. Construction .....	7
3.1 Construction views .....	7
4. Building and space requirements .....	8
4.1 Wall fixings .....	8
4.1.1 Concrete wall .....	8
4.1.2 Light concrete wall .....	8
4.1.3 Insulated wall .....	8
4.1.4 Cavity wall .....	9
4.1.5 Steel guard .....	9
4.2 Fixing points .....	10
4.2.1 Fixing points .....	10
5. Service .....	11
Index .....	12



# 1. Description

## 1.1 Application

The handling of cooled or frozen food put high demands on the temperature chain. The Crawford 671 inflatable shelter SIR provides the optimal sealing of temperature controlled premises during the loading and unloading process. Contrary to other types of dock shelters, the vehicle does not push towards the shelter. Instead, the shelter is air inflated around the docked vehicle, providing complete sealing. The Crawford 671 inflatable shelter SIR is suitable for all vehicle sizes and its sealing capacity exceeds by far the standard normally required by the operators.

## 1.2 Mode of operation

When a vehicle is positioned at the docking station, the Crawford 671 inflatable shelter SIR is activated by the control unit. The side bags inflate. The top part is a roller curtain. A unique balancing system makes the top roller curtain "free floating" when the vehicle is docked to the dock shelter.

During loading/unloading the vehicle moves up and down and the top roller curtain automatically follows these movements, without starting the roller curtain machinery. The roller guidance design includes a unique Break-Away system to follow horizontal movements. In rest position the bags are held in place mechanically.

## 1.3 Overview

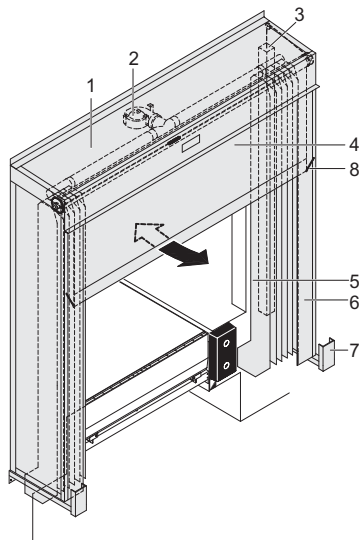

- 1 Insulated panels
- 2 Blower
- 3 Counter balance
- 4 Top curtain
- 5 Side bag
- 6 Curtain strips
- 7 Steel guard
- 8 Break-Away system

## 1.4 Standard

Nominal height	4055, 4355, 4555 mm	
Nominal width	3600 mm	
Nominal depth	770 mm	
Top curtain extension	2200 mm	
Side bag extension	650 mm	
Insulated panel	42 mm	
Operating	Switch control	
Standard colour	Insulated panel	RAL 9016
	Front plate	RAL 9016

Steel guard combi

Dock shelter is prepared for installation to wall or Load House.

## 1.5 Options

Front plate	Digit on front plate
Side bags	Wear shields
Colour	Insulated panel in special colour Front plate in special colour
Wall fixings	Concrete, cavity, insulated panel, light concrete, Load House

### 1.5.1 Option wear shield

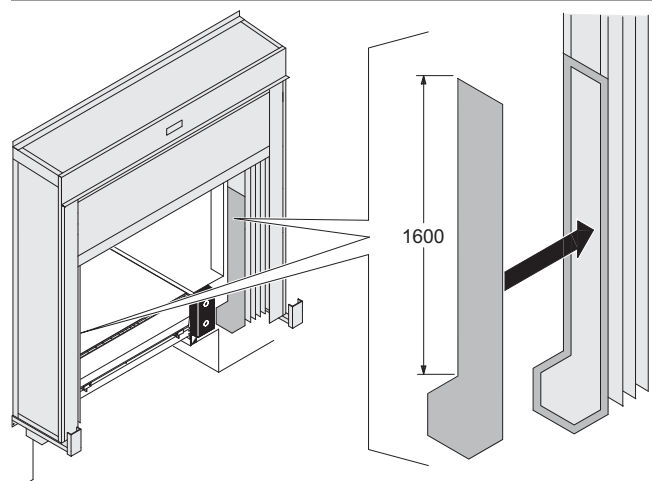

Extra layer of 3 mm PE curtain riveted to side bags to cover the lowest part left and right in the vehicle contact area. When the vehicle moves up and down during loading/unloading the side bags are protected against damages.

## 2. Specifications

### 2.1 Dimensions



Abb.	Dimension	Value (mm)
NW	Nominal width	3600
NH	Nominal height	4055, 4355, 4555
FH	Free height above level*	3600, 3900, 4100**
OP	Top curtain travel	2200
ND	Nominal depth	770
RH	Dock height	VH+500
MH	Installation height	
VH	Vehicle height	

\* depending on MH (installation height)

\*\* maximum sizes

## 3. Construction

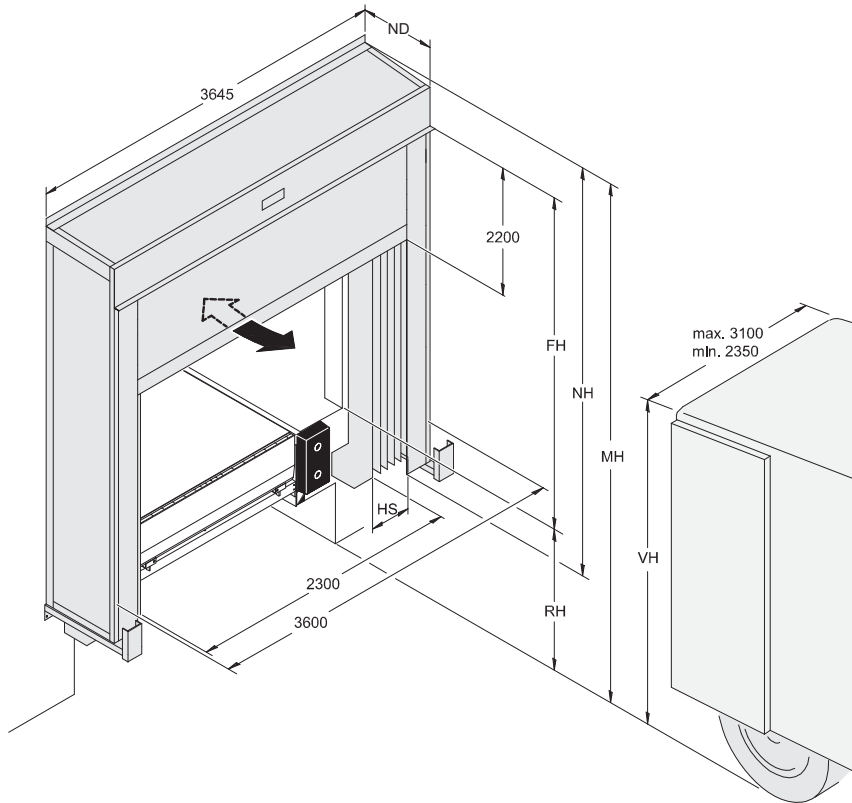
The Crawford 671 inflatable shelter SIR can be fitted directly to the wall or on a Load House and is available as a single module or multiple modules. The Crawford 671 inflatable shelter SIR consists of two side walls with bags (one side wall for multiple module), front protections and installation material. Roof with top curtain, front plate, machinery, fan and installation brackets. The Crawford 671 inflatable shelter SIR is operated from a control panel and the supply contains the complete dock shelter including necessary fixings.

A spring tension device minimises the risk of damages from vehicles hitting the structure during docking manoeuvres. The Crawford 671 inflatable shelter SIR is designed to provide the best seal possible around the vehicle.

### 3.1 Construction views

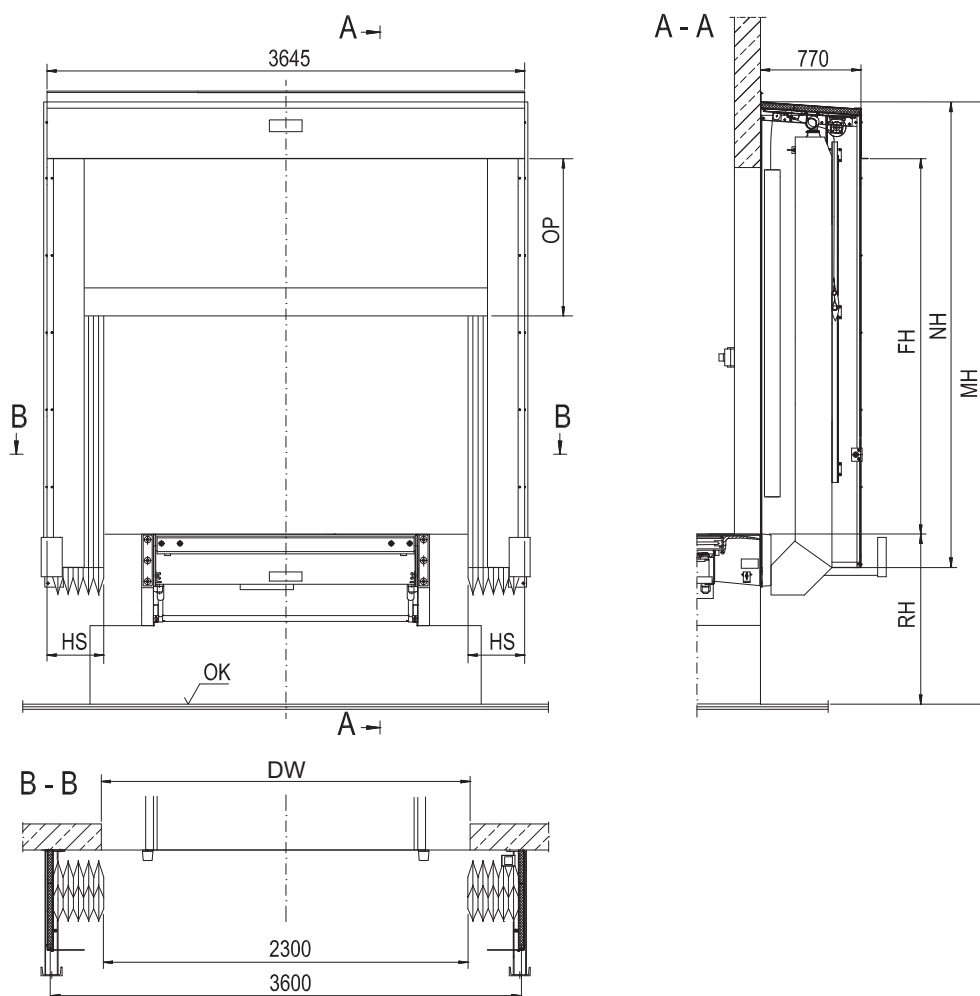

OK	Yard level
DW	Door width
NH	Nominal height
RH	Dock height
OP	Top curtain travel (OP = 2200 mm)
HS	Side bag extension
FH	max. free height above dock level (depending on MH)
MH	Installation height (VH+500 mm)

# 4. Building and space requirements

## 4.1 Wall fixings

### 4.1.1 Concrete wall

Top

Side

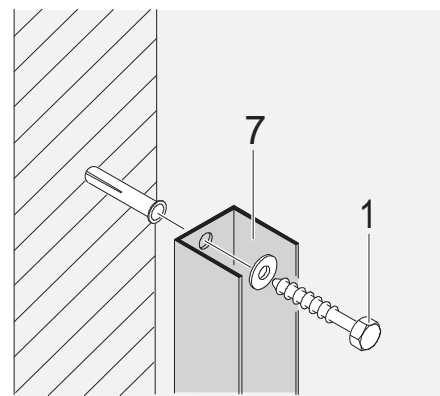
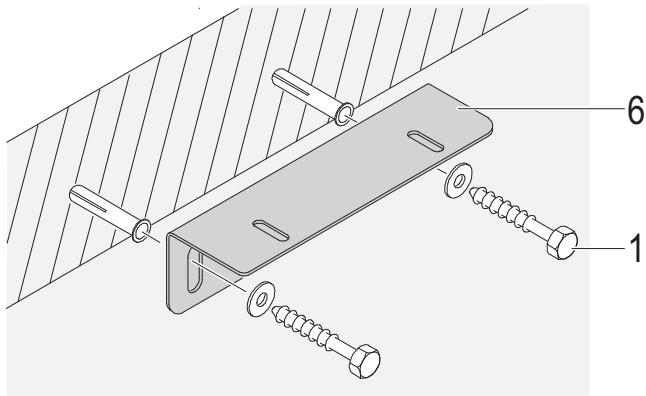

### 4.1.2 Light concrete wall

Top

Side

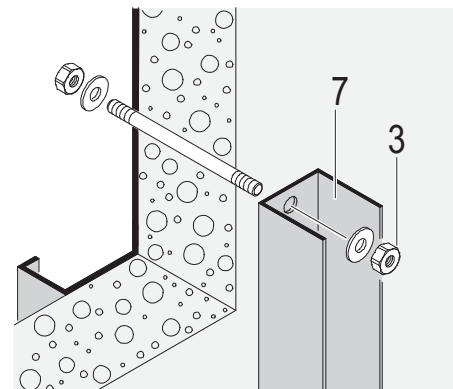
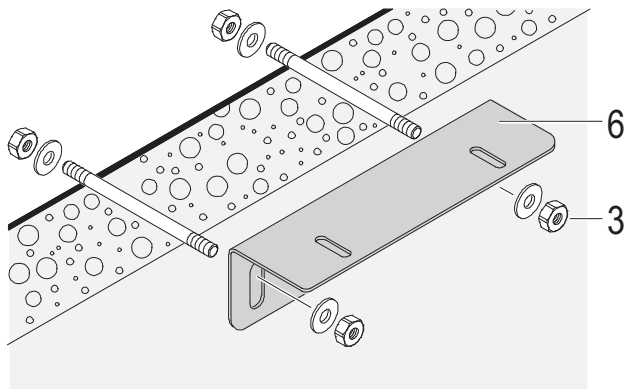

### 4.1.3 Insulated wall

Top

Side

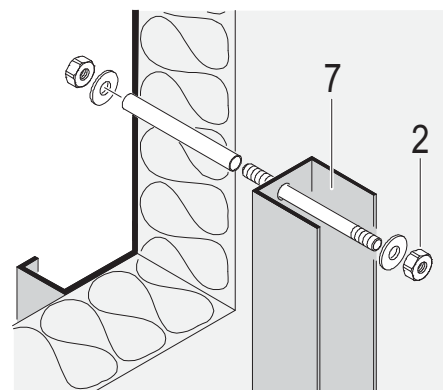
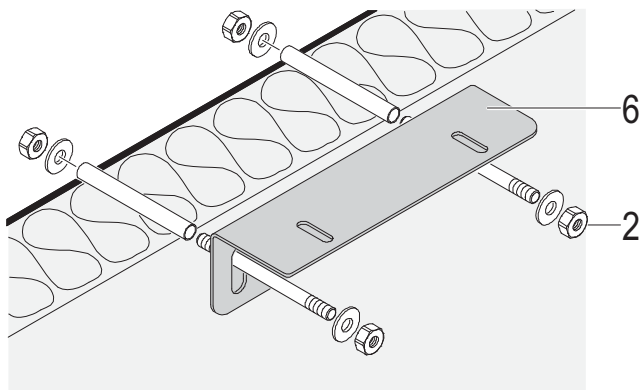





#### 4.1.4 Cavity wall

Top

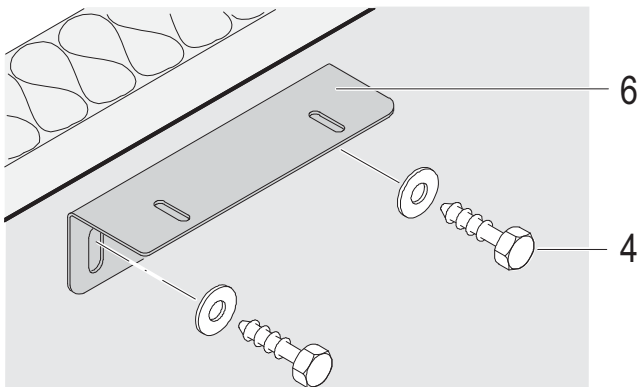

Side

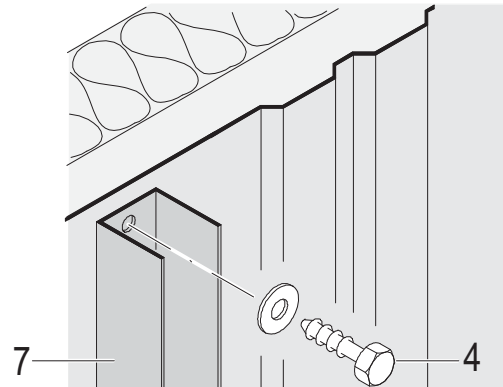

#### 4.1.5 Steel guard

Left

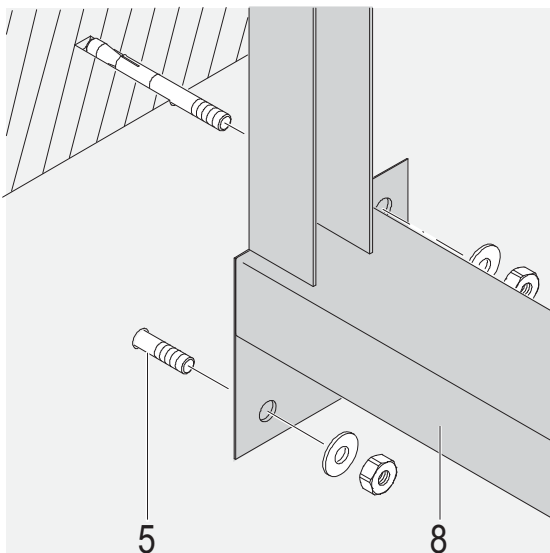

Right

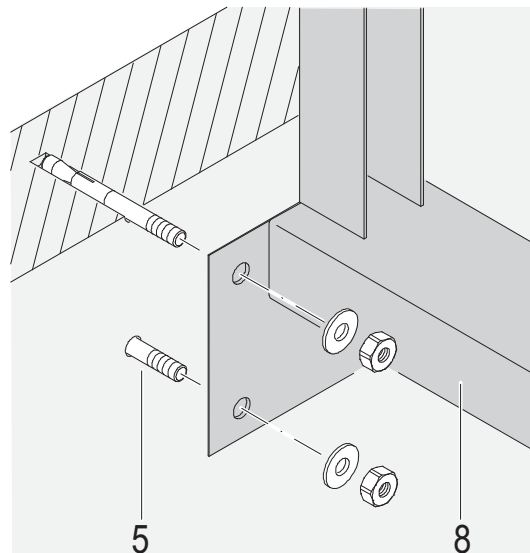

- 1 Screw with dowel 8x60
- 2 Threaded bolt with nut and washer\*\*
- 3 Hexagonal nut with washer
- 4 Self tapered screw 8x32
- 5 Heavy duty bolt M12 \*\*
- 6 Support bracket \*\*
- 7 U-profile 55x45x1
- 8 Steel guard

\* by others, not included in the delivery

\*\* belong to the wall fixing

**Note!**

The wall surface at the installation point, NH + 150 mm (measured from the top edge of the impact bar) and NB + 100 mm, should be smooth and flat. The same applies for the fixing of the impact bar.

## 4.2 Fixing points

### 4.2.1 Fixing points

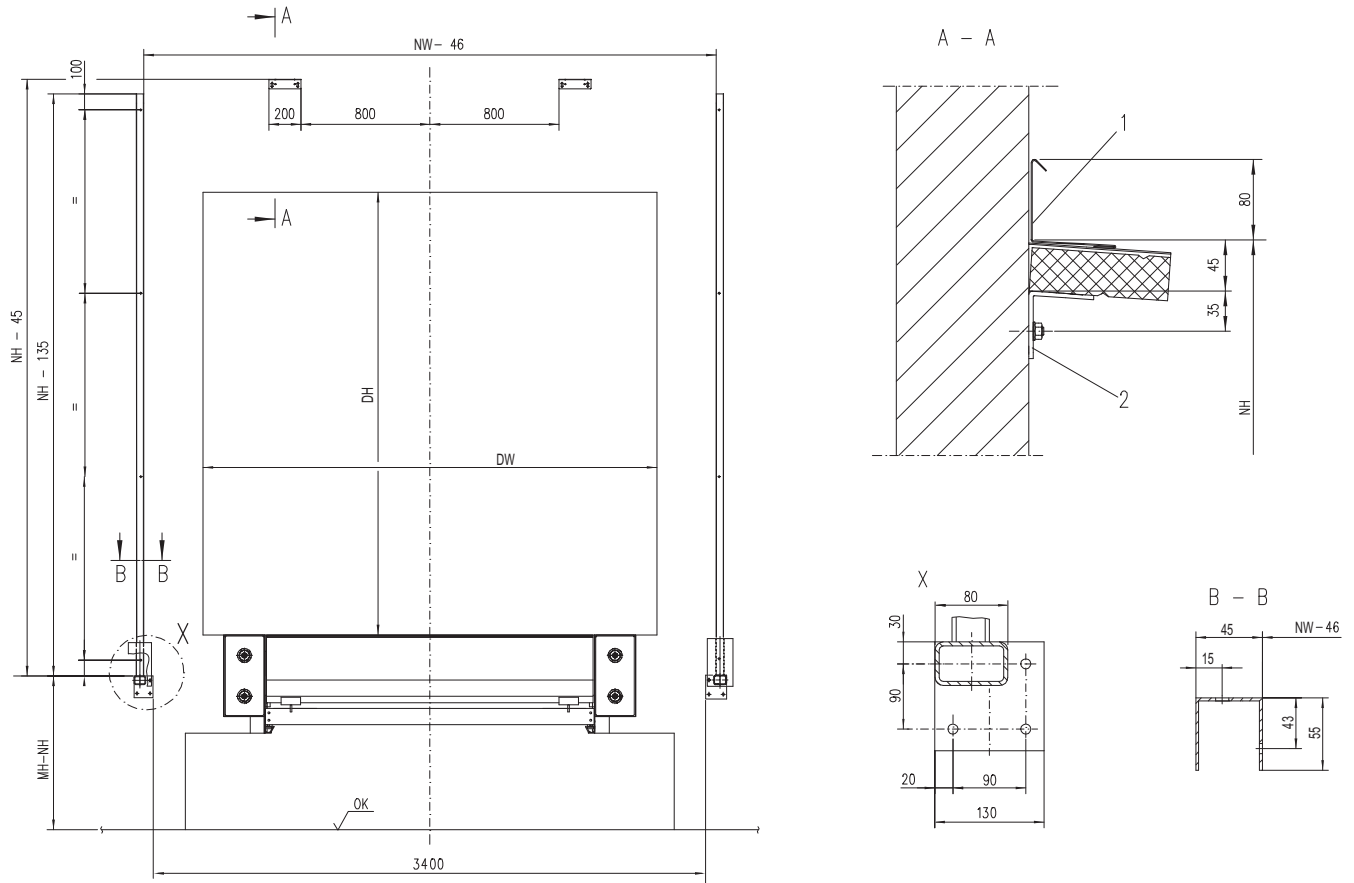

1 Wall mounting profile\*

2 Support bracket\*

\* belongs to the wall fixing

# 5. Service

## Preventive Maintenance Program and Modernization Services

As your entrances are part of your business flow, there's every reason to keep them working well. ASSA ABLOY Entrance Systems offers you a maintenance and modernization expertise to rely on. Our Maintenance Programs and Modernization Services are backed by a extensive expertise for all types of industrial door and docking systems, independent of brand. At your disposal is a team of dedicated expert technicians, proven through decades of maintenance, service and satisfied customers.

### Preventive Maintenance Programs

Minimizing lost time, lost energy and unexpected hassle is our team's constant objective. Our service organization can support you 24/7 in maintaining all industrial door and docking systems, independent of brand. If you want to be one step ahead of break-downs, explore our portfolio of Pro-Active Care plans. Naturally, we also offer entrance upgrades to suit your specific wishes and business needs.

### Pro-Active Care - Maintenance plans to fit your business

Regular maintenance can extend the lifetime of your equipment and help prevent unexpected problems. Our technician arrives on-site equipped with the knowledge and tools to service all automatic entrances, independent of brand.

- **Pro-Active Bronze**

The base on which all Pro-Active Plans are built provides the security of knowing that your equipment is regularly inspected and certified for safety, as well as performing optimally. It includes a number of planned on-site visits depending on your needs. Any unplanned service calls required during the term of the contract (including labor, travel and parts) are billed at special Pro-Active Care prices.

- **Pro-Active Silver**

This plan provides all the benefits of Pro-Active Bronze with the added advantage of labor and travel being included for service calls during regular business hours. The only additional charge would be for any parts that may be needed throughout the term of the contract.

- **Pro-Active Gold**

This plan provides the ultimate protection for your automatic entrance investment. It includes all the benefits of Pro-Active Silver, plus replacement of any parts required during an unplanned repair or planned maintenance visit. Pro-Active Gold is an excellent way to budget your automatic door expenses annually.

- **Pro-Active Tailor-Flex**

Our most flexible maintenance and service offering. The Pro-Active Care plan is designed by you, our customer. The plan allows you to balance your maintenance expenses against your real-world budget and presents the option to add or delete a number of maintenance elements to suit your budget goals, while meeting your overall performance and safety needs.

### Modernization

Your entrances are a long-term investment, from which you always want the best. Products develop over time, so do regulations and your business. Let us help you increase energy savings and meet today's standards. We provide advice and modernization kits for outdated installations, ensuring your investment meet requirements and performs optimally for many more years to come.

Re-Active Service		Pro-Active Care				
		Pro-Active Bronze	Pro-Active Silver	Pro-Active Gold	Pro-Active Tailor Flex	
		○	○	○	●	Other customized requests such as Response Time, Performance InfoPack and Advanced User Training
		○	○	●	○	Replacement of worn parts according to preventive Consumable Exchange Program
		○	○	●	○	Replacement of spare parts on breakdowns
		○	●	●	○	Travel and labor for additional call-out visits
		●	●	●	●	Preventive maintenance visits 1-4 times per year
		●	●	●	●	Travel and labor for preventive maintenance visits
		●	●	●	●	Response time and priority on call-outs <24h
		●	●	●	●	Preventive planned maintenance that meets the most demanding standards in the market
	●	●	●	●	●	Safety and quality checks according to applicable regulations and norms. Documentation of test results provided
●	●	●	●	●	●	Documentation of equipment status, assessment and service provided, all generated on site
●	●	●	●	●	●	Highly trained professional technicians with extensive knowledge, state-of-the-art tools and the right spare parts*
●	●	●	●	●	●	Dedicated Professional Customer Care Hotline
Corrective	SafetyCheck	Pro-Active Bronze	Pro-Active Silver	Pro-Active Gold	Pro-Active Tailor Flex	

● = Included as standard

○ = Available at special prices

\* Well-stocked service vehicles with genuine and new spare parts

# Index

<b>A</b>		<b>T</b>	
Application .....	5	Technical facts .....	3
<b>B</b>		<b>W</b>	
Building and space requirements .....	8	Wall fixings .....	8
<b>C</b>			
Cavity wall .....	9		
Concrete wall .....	8		
Construction .....	7		
Construction views .....	7		
Copyright and Disclaimer Notice .....	2		
<b>D</b>			
Description .....	5		
Dimensions .....	6		
<b>F</b>			
Features .....	3		
Fixing points .....	10		
<b>I</b>			
Insulated wall .....	8		
<b>L</b>			
Light concrete wall .....	8		
<b>M</b>			
Mode of operation .....	5		
<b>O</b>			
Option wear shield .....	5		
Options .....	5		
Overview .....	5		
<b>P</b>			
Performance .....	3		
<b>S</b>			
Service .....	11		
Specifications .....	6		
Standard .....	5		
Steel guard .....	9		



ASSA ABLOY Entrance Systems is a leading supplier of entrance automation solutions for efficient flow of goods and people. With our worldwide presence we offer products and services dedicated to satisfying end-user needs for safe, secure, convenient and sustainable operations. ASSA ABLOY Entrance Systems is a division within ASSA ABLOY.

**ASSA ABLOY**

[www.assaabloyentrance.com](http://www.assaabloyentrance.com)